



MINISTERO  
DELLA DIFESA



ESERCITO

# 10° REPARTO INFRASTRUTTURE NAPOLI

Seminario tecnico

## **BONIFICA DAGLI ORDIGNI BELLICI**

Ordine degli Ingegneri della Provincia di Napoli

NAPOLI 28 MAGGIO 2018

## **METODI E STRUMENTI DI RICERCA**

**RELATORI:**

**DT B.C.M. Magg. Diego COSENZA**

**Ufficio BCM - NAPOLI**



ESERCITO

# SOMMARIO

**Magnetometria**

**Magnetometri**

**Software  
elaborazione dati**

**Metodo  
elettromagnetico**



# ***MAGNETOMETRIA***

- Si basa sulla misura dell'interferenza, generata dagli oggetti ferromagnetici, sul Campo Magnetico Terrestre (CMT) [unità gamma, Tesla];
- Le misure possono essere riferite ad una stazione fissa sul sito oppure effettuate in configurazione gradiometrica al fine di escludere variazioni di campo dovute alle fluttuazioni naturali del Campo Magnetico Terrestre;



ESERCITO

# MAGNETOMETRIA

- Il magnetometro misura l'intensità del campo magnetico terrestre.
- La presenza di materiale *ferromagnetico* crea delle variazioni nel campo magnetico locale, consentendo così l'individuazione di oggetti.
- La risposta di un magnetometro dipende dalla massa e dalla profondità a cui si trova l'oggetto metallico.
- Metalli *non ferromagnetici*, quali l'alluminio, il rame e lo stagno, non inducono anomalie del campo magnetico.
- Inoltre, nell'esplorazione di aree localizzate le condizioni delle proprietà magnetiche diversificate dei terreni, delle rocce e dei materiali inducono anomalie magnetiche.
- Una concentrazione di minerali ferrosi o di oggetti sepolti producono variazioni del campo magnetico locale che possono essere rilevate in superficie.



# MAGNETOMETRIA



ESERCITO

- La forma delle linee di forza del *campo magnetico terrestre* sono simili a quelle che potrebbe creare una barra magnetica disposta verticalmente dal polo sud al polo nord.

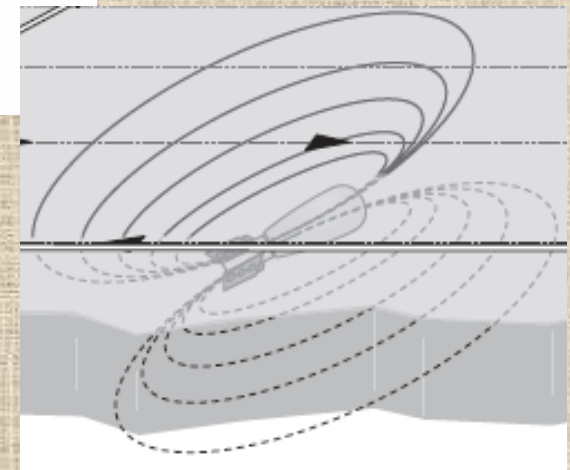
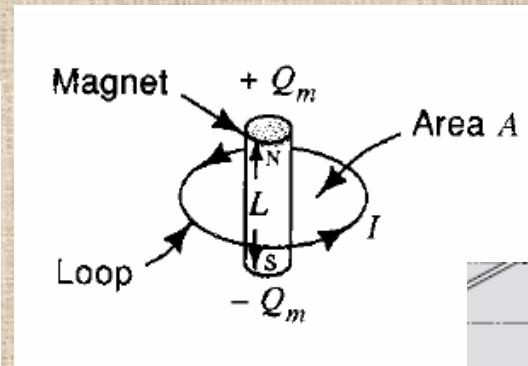
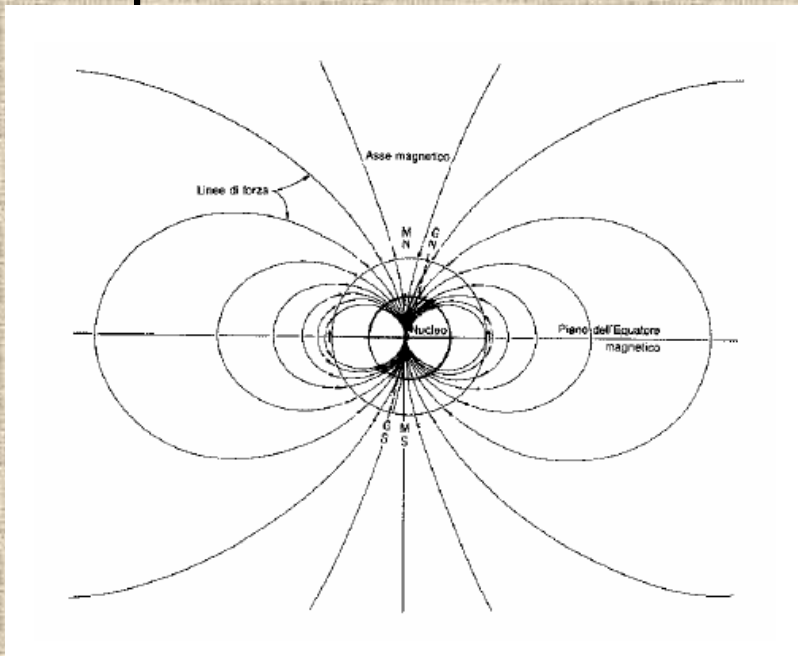



ESERCITO

# MAGNETOMETRIA

Change in Magnetic Field  
(gammas)

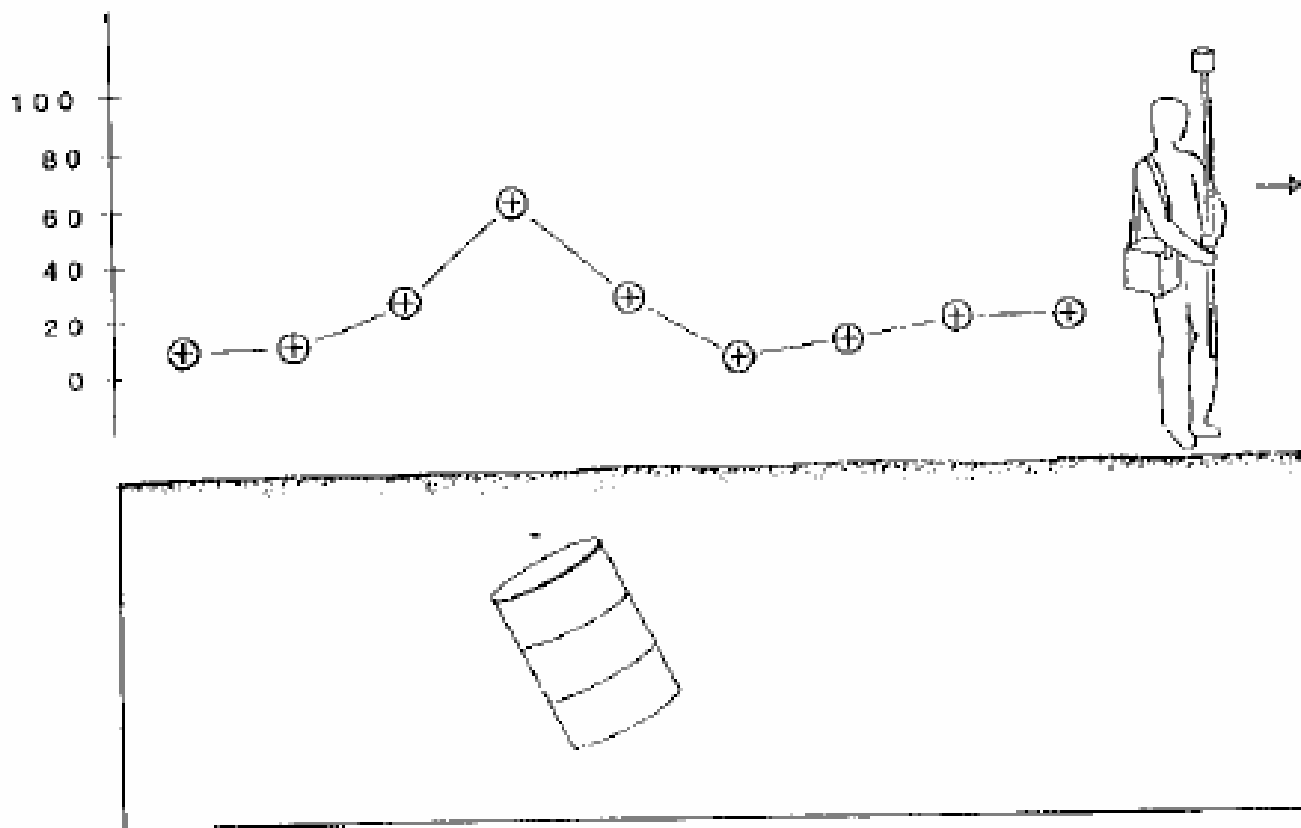



ESERCITO

# MAGNETOMETRIA

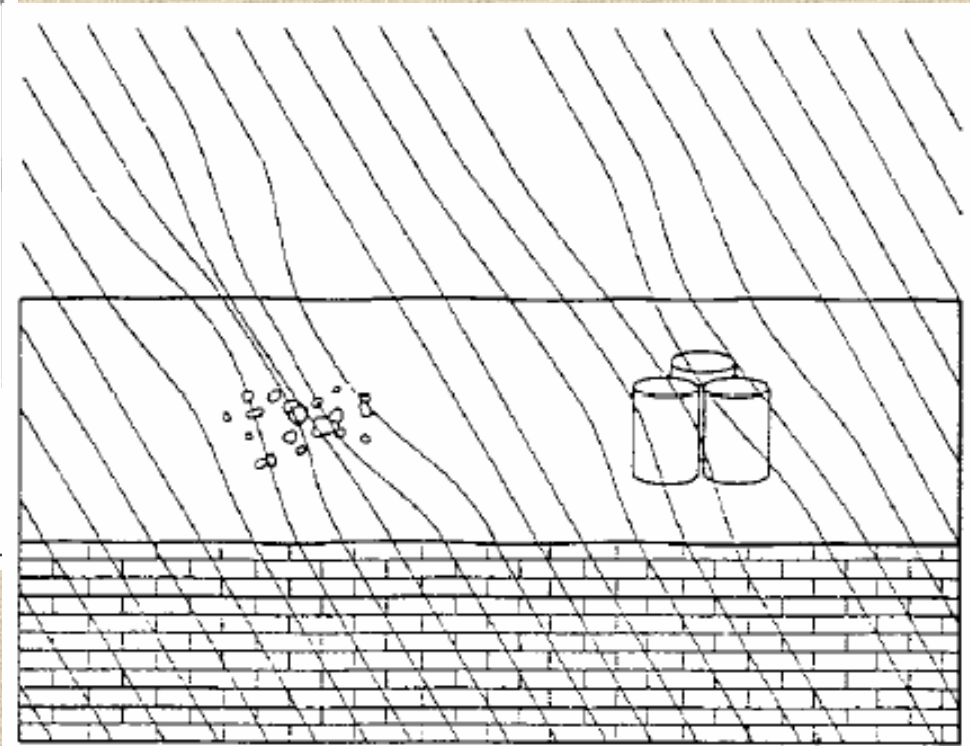
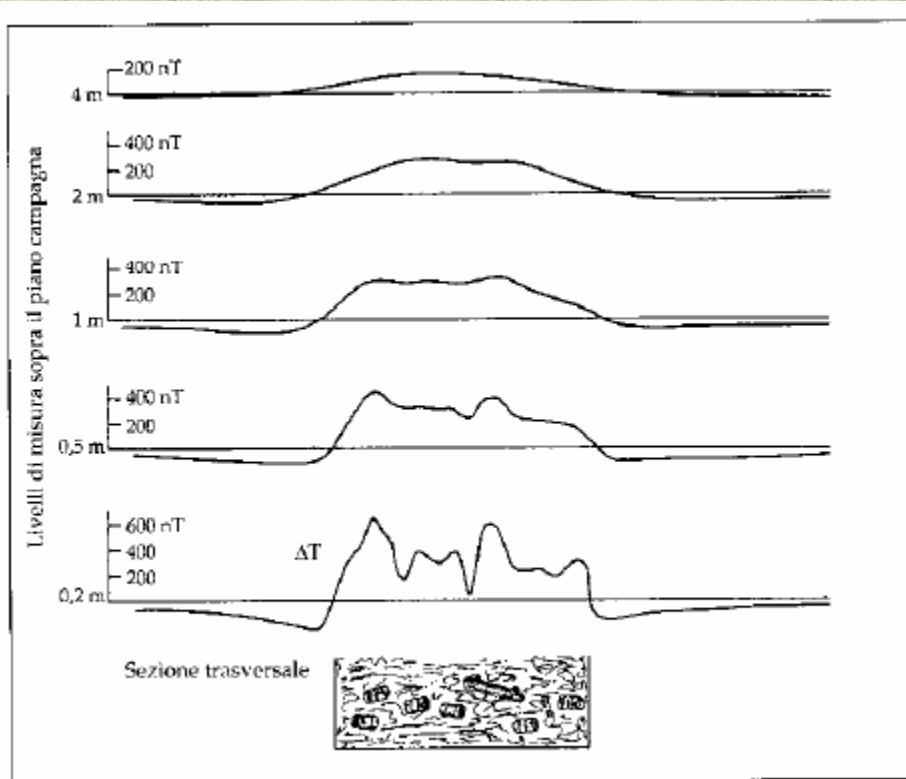



ESERCITO

# MAGNETOMETRI

- Esistono diversi tipi di magnetometri:
- magnetometro *fluxgate*, magnetometro a protoni, magnetometro al cesio.
- Nel magnetometro *fluxgate* il sensore è costituito da un nucleo ferromagnetico che subisce variazioni di saturazione di magnetizzazione con l'ambiente circostante. Tali variazioni sono proporzionali all'intensità del campo. Elettronicamente le variazioni vengono amplificate e registrate. Il *fluxgate* è molto sensibile a variazioni d'inclinazione dello strumento cosicché viene accoppiato con un *gradiometro* per l'orientazione, oppure vengono combinati due *fluxgate* insieme con un *radiometro*.
- Nel magnetometro a protoni viene generato un campo magnetico intorno ad un fluido di una sostanza particolare. Il campo creato produce una orientazione dei protoni del fluido. Nel momento in cui il campo magnetico viene annullato, il movimento di *spin* dei protoni si orienta secondo il campo magnetico totale. La loro precessione nucleare genera un segnale la cui frequenza è proporzionale all'intensità del campo. Viene così misurata direttamente l'intensità del campo magnetico locale.





# MAGNETOMETRI

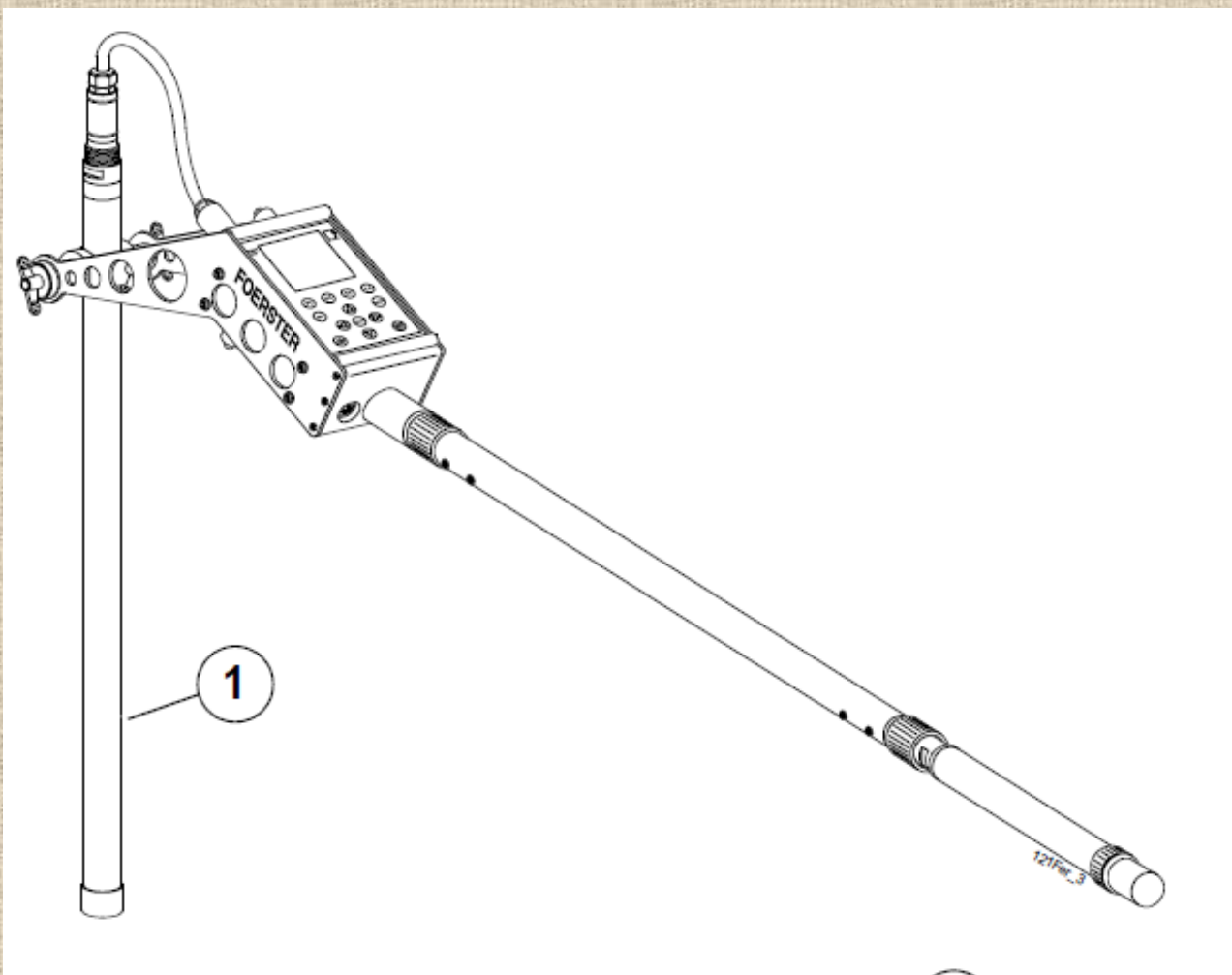



# MAGNETOMETRI

- Le misure vengono realizzate secondo profili o secondo grid regolari;

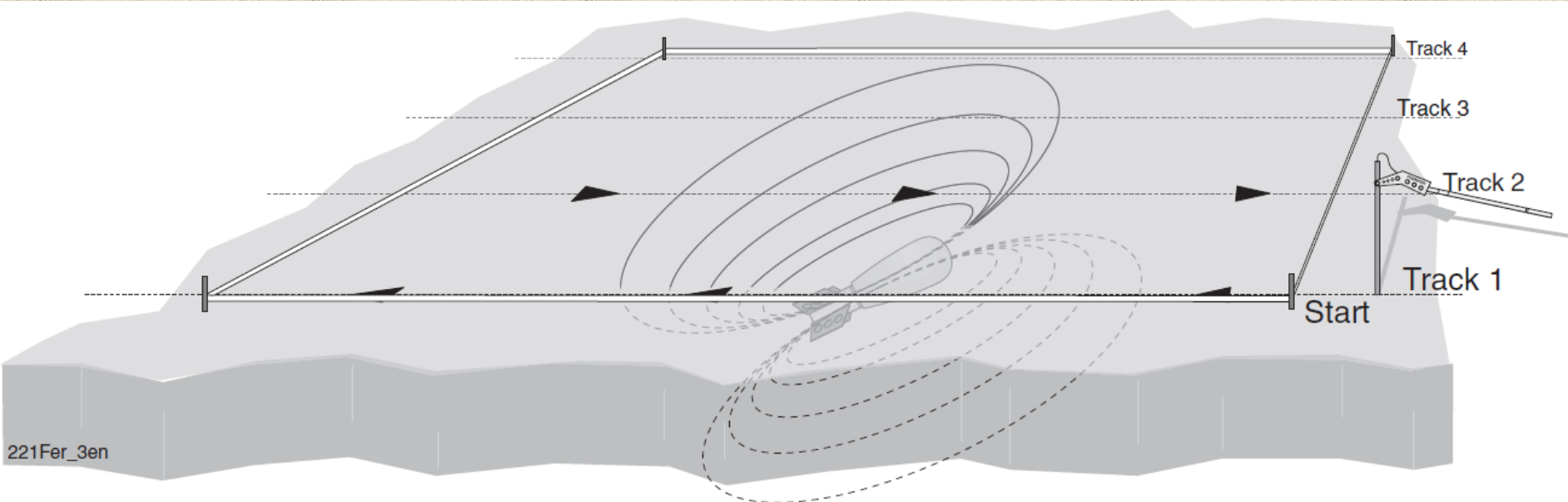



# MAGNETOMETRI



ESERCITO

*Cavo di collegamento con prolunga, per l'inserimento della sonda nei fori di accertamento in profondità.*

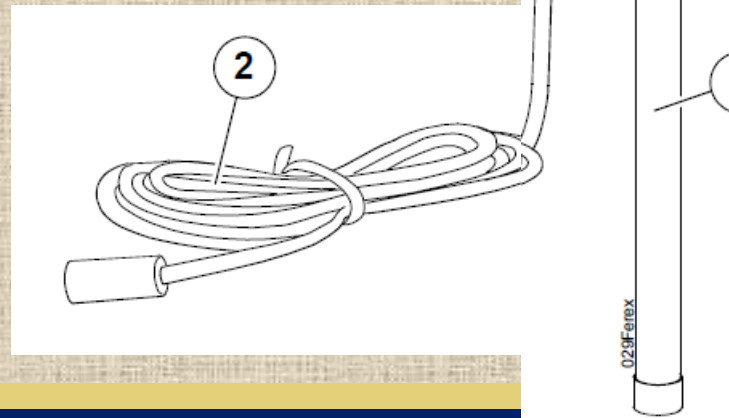



# MAGNETOMETRI

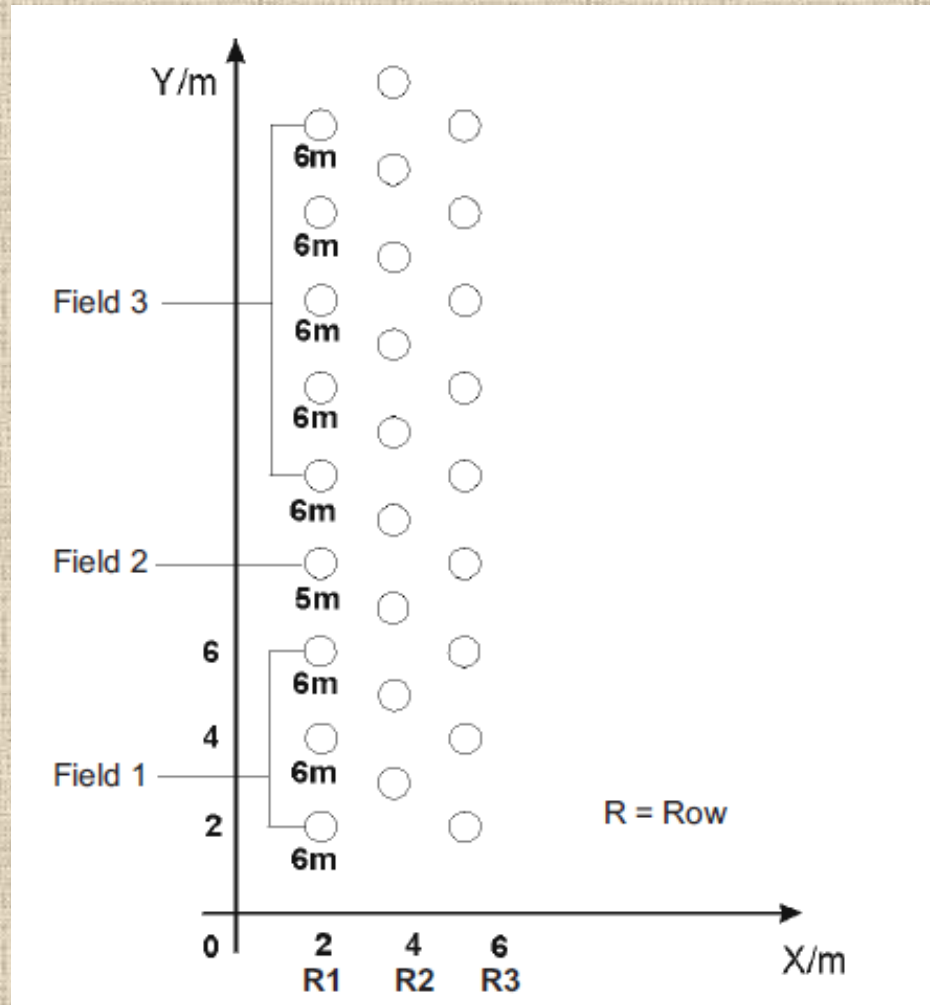



# MAGNETOMETRI



ESERCITO

FEREX  
4.032

PROBE: 1

MEASURE

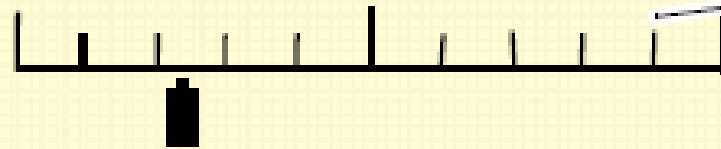

-05125.6

S E N: 10000nT

MOD: 1 16Hz

MOD

SEN

CHA



Use the up/down arrows to choose the measuring range:  
3; 10; 30; 100; 300; 1000; 3000 and 10000 nT, as well as LOG (10000 nT).



# MAGNETOMETRI



ESERCITO

You can choose between six different sound modes:

MOD: 1 = 16 Hz Notch filter  
 MOD: 2 = 50 Hz Notch filter  
 MOD: 3 = 60 Hz Notch filter  
 MOD: 4 = 200 Hz Notch filter  
 MOD: 5 = 0.2 Hz (Low-pass)  
 MOD: 6 = HP (High-pass)

No.	Mode	Settings/procedure	Remark	Detection speed specifications
1	Mode 1	Suppresses interference, particularly that caused by the 16 2/3 Hz power supply of railways.	Responds somewhat slowly.	Up to 11 km/h = 3.1 m/s
2	Mode 2	To be used when effective suppression of 50 Hz interference fields is required.	To be used when Mode 1 is too slow.	Up to 33.5 km/h = 9.3 m/s
3	Mode 3	To be used when 60 Hz interference fields need to be suppressed effectively.		Up to 40.3 km/h = 11.2 m/s
4	Mode 4	Mode 4 operates over a wide band and therefore provides the fastest data logging.	Power supply lines are logged and represented by the symbol  on the display of the operator-control unit. An acoustic signal is also emitted.	Up to 133.9 km/h = 37.2 m/s
5	Mode 5	Mode 5 is an extremely slow mode. Small objects are suppressed.	Mode 5 is ideal for detecting large objects.  A fixed, constant swivel speed is required.	Up to 0.5 km/h = 0.14 m/s
6	Mode 6	Mode 6 can be used to blank out constant interference signals. Signals of this kind may come from railway lines, fences, masts, etc.  This mode is particularly ideal for detecting small objects located near the surface.	A relative probe swivel speed is important here.	From 9 km/h = 2.5 m/s to 11.2 km/h = 3.1 m/s



# *Software elaborazione dati*



- Utilizzando strumenti dotati di software di registrazione ed elaborazione automatica dei dati, eventualmente integrati anche con sistemi di georeferenziazione (GPS), si ottiene una mappatura degli oggetti sepolti, realizzando cartografie che illustrano per isolinee, in planimetria, il gradiente/CMT.



# Software elaborazione dati



ESERCITO

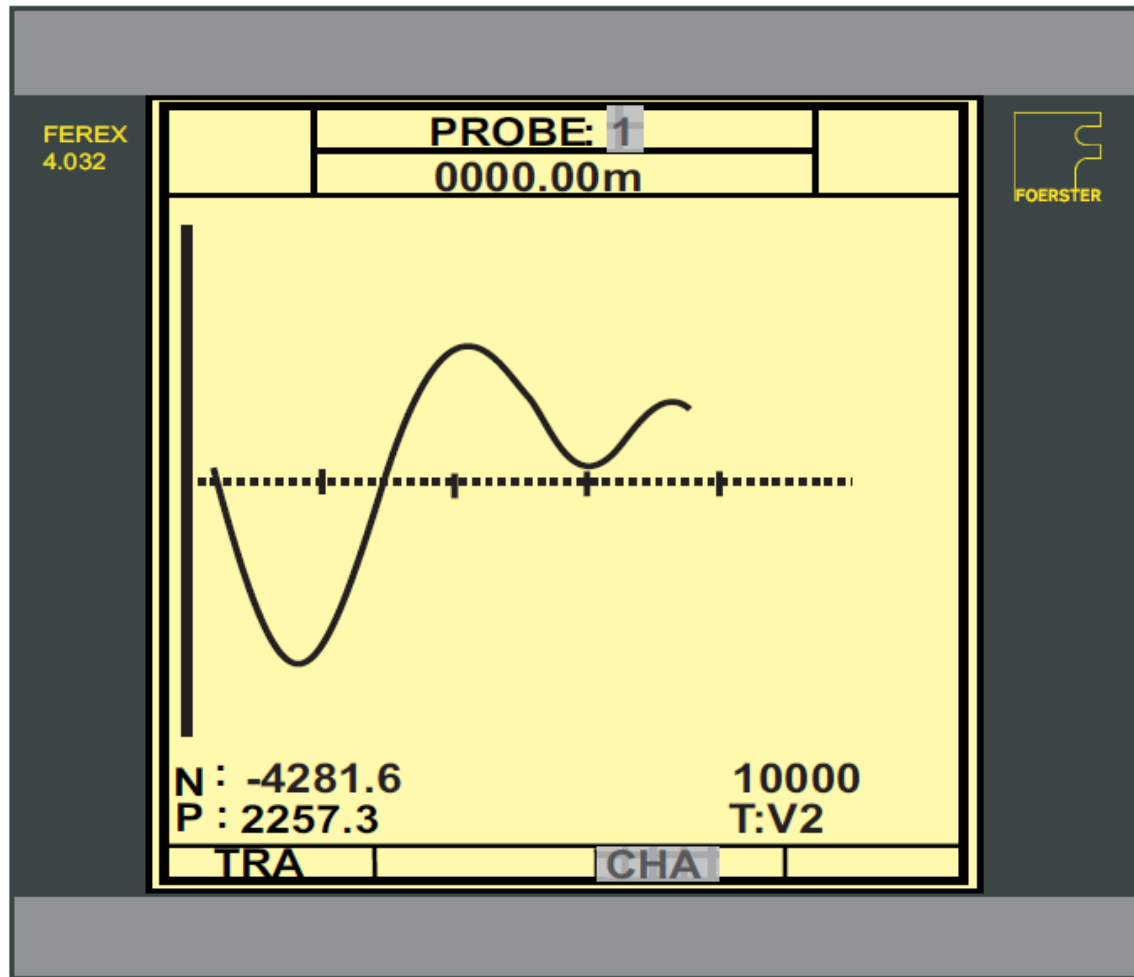





# Software elaborazione dati



ESERCITO

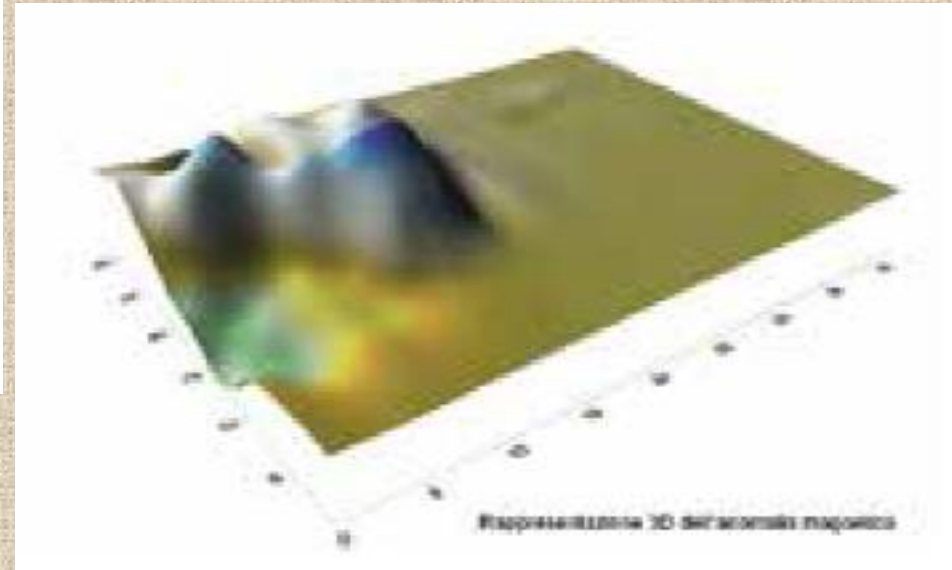
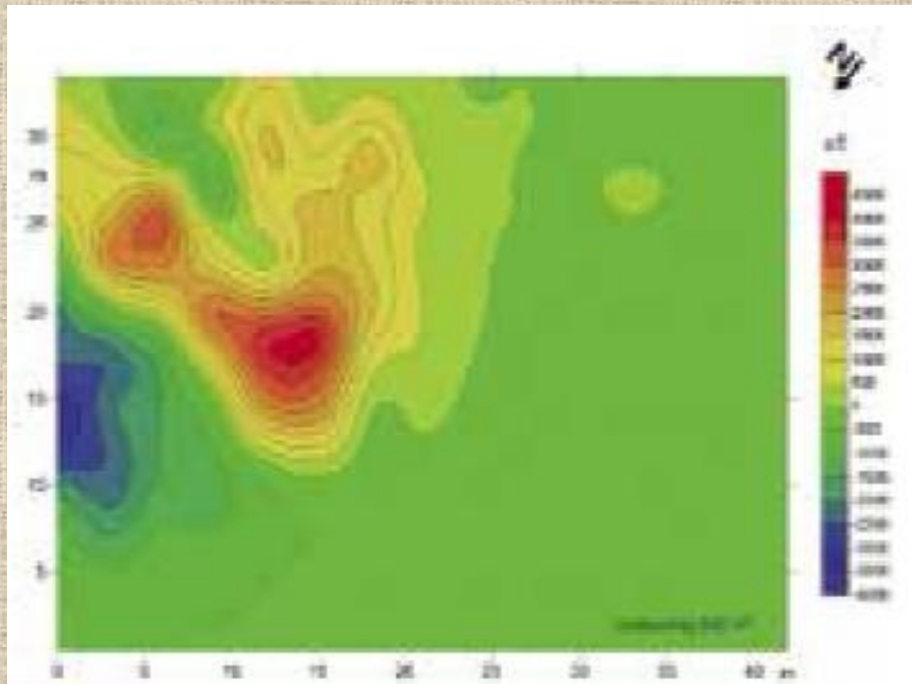



# Software elaborazione dati



ESERCITO

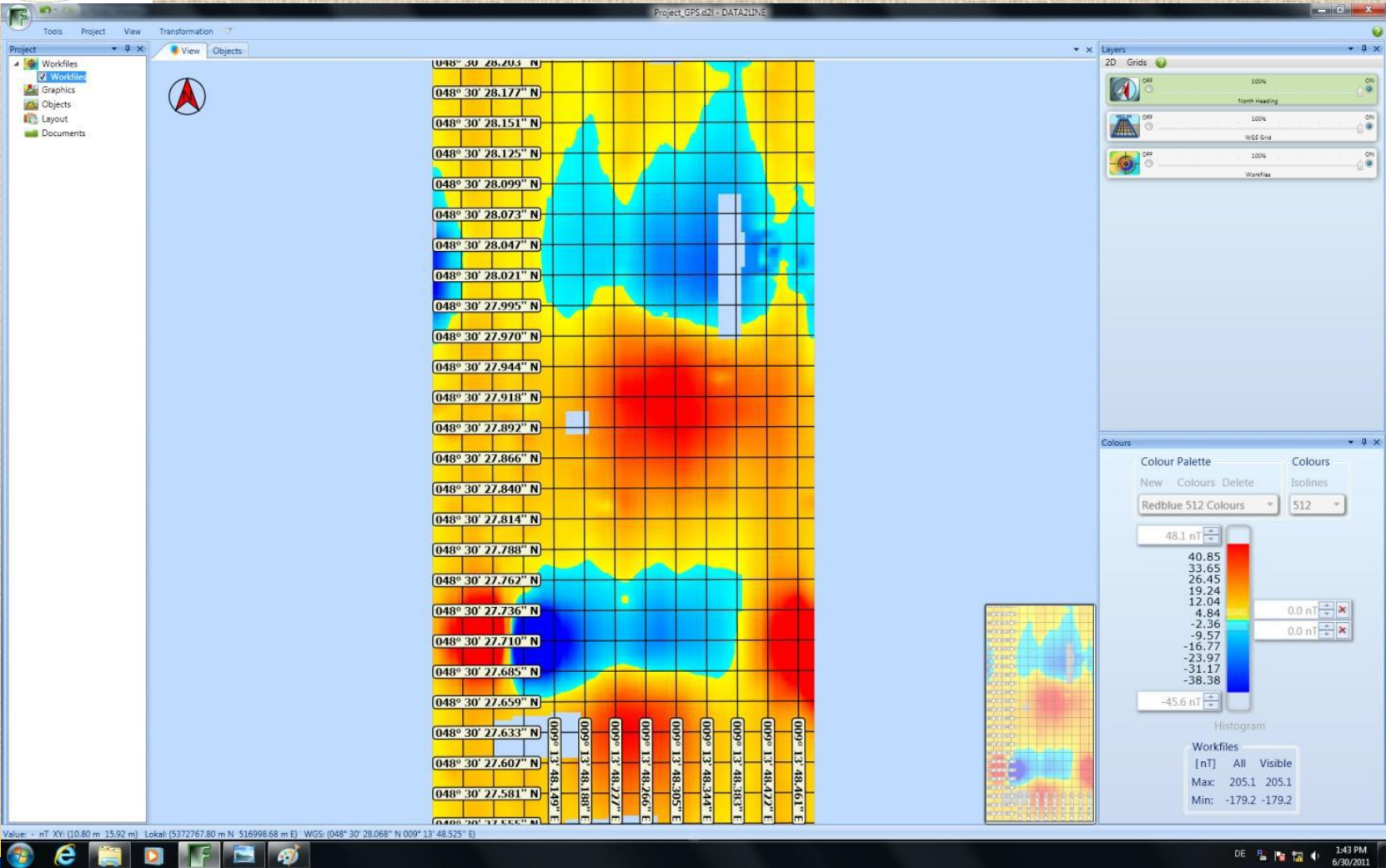



# Software elaborazione dati

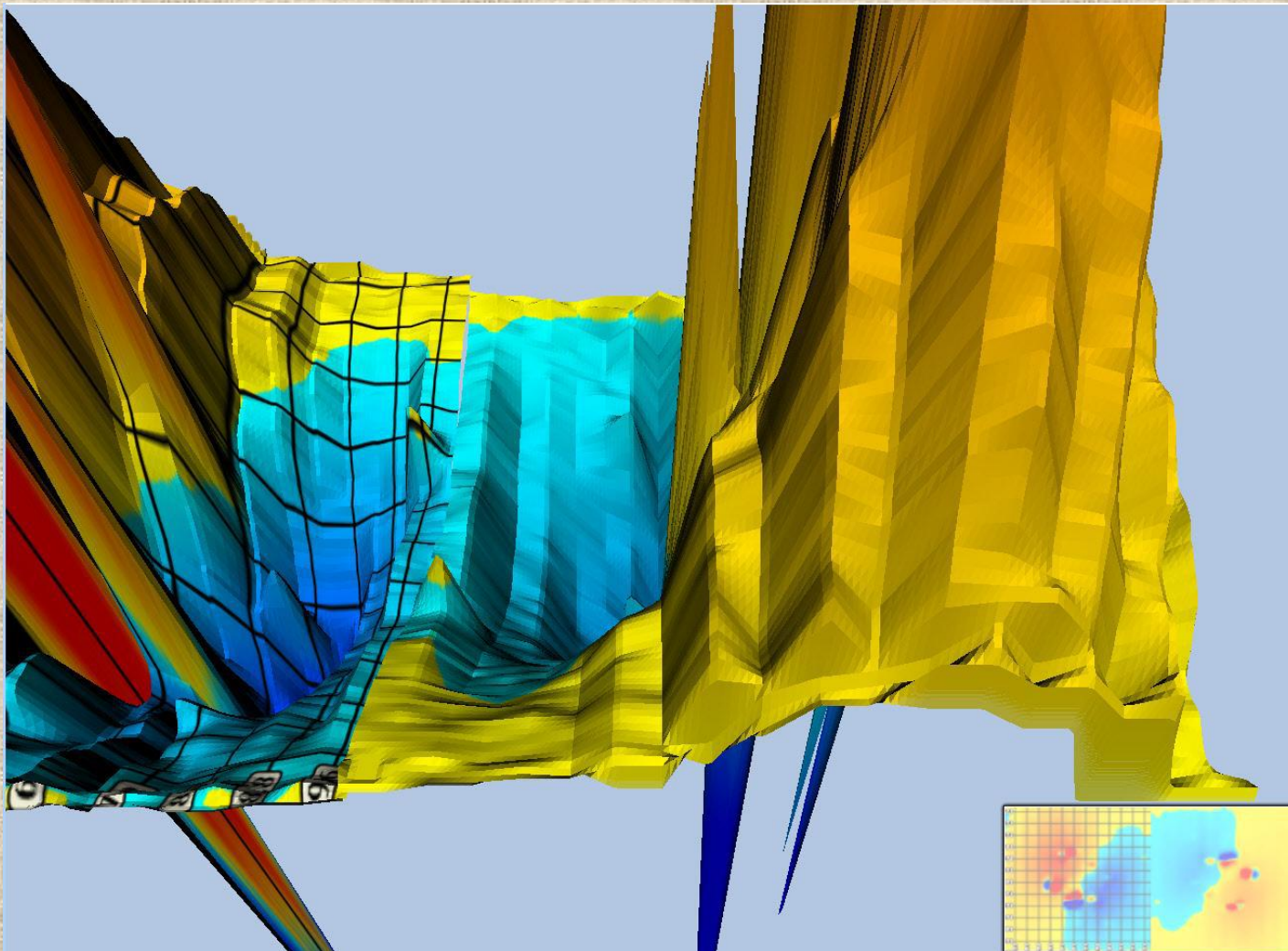



# Software elaborazione dati

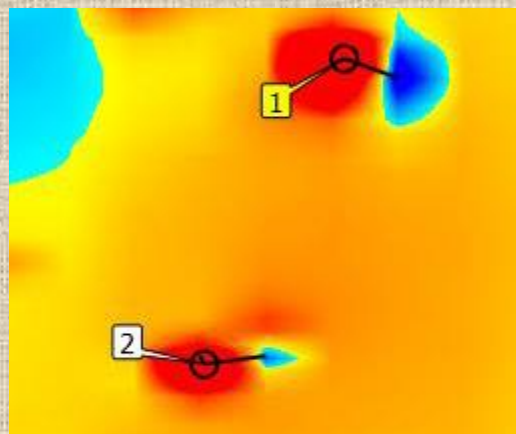

Origin	ID	View	Label	List	Quality [%]	X-Position [m]	Y-Position [m]	Depth [m]	Inclination [°]	Declination [°]	Diameter [m]	Magn. Moment [Am <sup>2</sup> ]	Volume [l]	Local X [m]	Local Y [m]	Latitude [°]	Longitude [°]
	1	<input checked="" type="checkbox"/>	<input checked="" type="checkbox"/>	Objects_1	81.1	23.97	55.45	2.06	-42.8	69.9	1.16	97.85	815.452	854344.20	6407053.60	057° 39' 56.801" N	014° 56' 38.658" E
	2	<input checked="" type="checkbox"/>	<input checked="" type="checkbox"/>	Objects_1	42.0	16.58	58.13	1.94	4.0	187.2	1.13	90.31	752.615	854336.83	6407056.30	057° 39' 56.909" N	014° 56' 38.229" E
	3	<input checked="" type="checkbox"/>	<input checked="" type="checkbox"/>	Objects_1	97.6	42.66	81.92	0.27	77.1	53.7	0.26	1.12	9.374	854362.98	6407080.01	057° 39' 57.597" N	014° 56' 39.924" E
	4	<input checked="" type="checkbox"/>	<input checked="" type="checkbox"/>	Objects_1	97.7	21.19	137.12	0.16	-15.1	321.9	0.07	0.02	0.165	854341.70	6407135.27	057° 39' 59.435" N	014° 56' 38.938" E
	5	<input checked="" type="checkbox"/>	<input checked="" type="checkbox"/>	Objects_1	97.4	34.27	140.41	0.17	24.0	309.6	0.07	0.02	0.157	854354.79	6407138.52	057° 39' 59.502" N	014° 56' 39.741" E
	6	<input checked="" type="checkbox"/>	<input checked="" type="checkbox"/>	Objects_1	96.6	30.73	138.57	0.32	1.9	221.7	0.09	0.05	0.437	854351.24	6407136.69	057° 39' 59.453" N	014° 56' 39.519" E
	7	<input checked="" type="checkbox"/>	<input checked="" type="checkbox"/>	Objects_1	94.3	28.04	127.52	0.38	-6.1	178.0	0.11	0.08	0.667	854348.52	6407125.65	057° 39' 59.106" N	014° 56' 39.297" E
	8	<input checked="" type="checkbox"/>	<input checked="" type="checkbox"/>	Objects_1	93.6	50.15	155.78	0.40	0.0	176.2	0.18	0.35	2.937	854370.72	6407153.84	057° 39' 59.950" N	014° 56' 40.778" E
	9	<input checked="" type="checkbox"/>	<input checked="" type="checkbox"/>	Objects_1	96.8	70.30	156.67	0.40	19.8	48.8	0.12	0.10	0.857	854390.87	6407154.66	057° 39' 59.919" N	014° 56' 41.992" E



# Software elaborazione dati

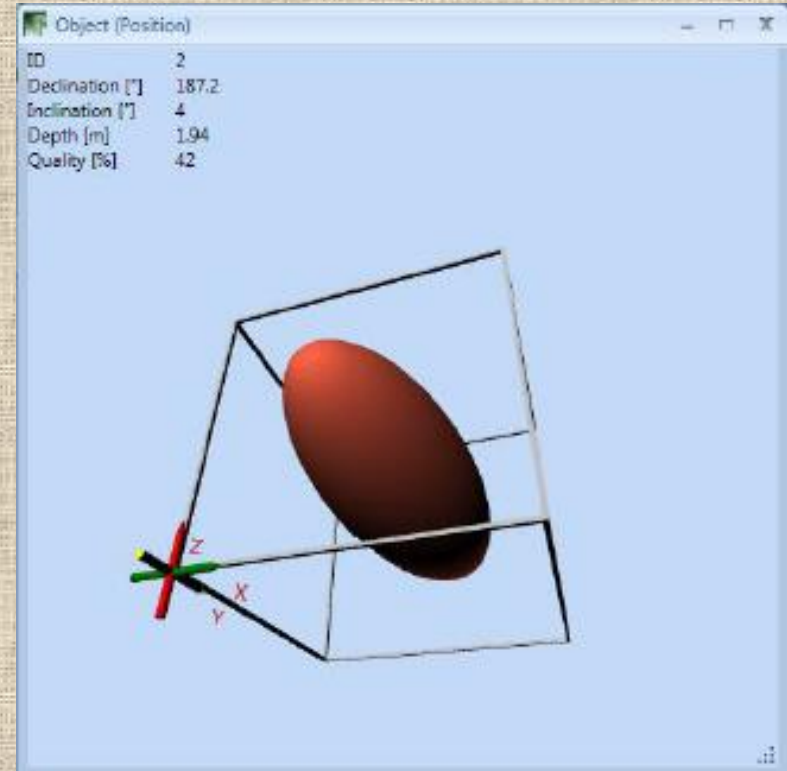
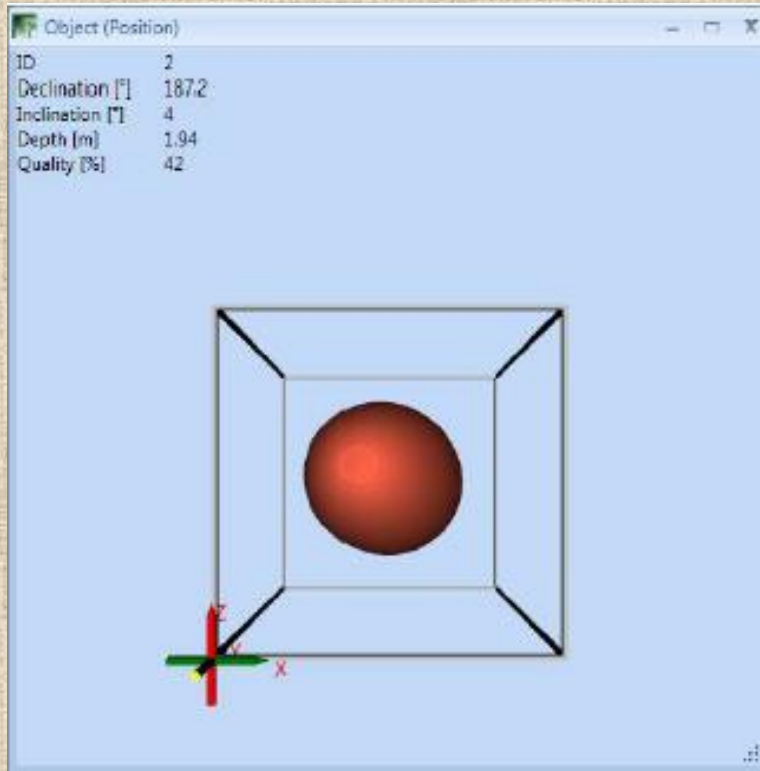



ESERCITO

# *Metodo ELETTRROMAGNETICO*

- Il metodo utilizza la generazione di un campo elettromagnetico, detto primario, che si trasmette intorno ad una bobina emittente, inducendo nel terreno una circolazione di una corrente.
- Questa originerà a sua volta un campo elettromagnetico secondario, la cui intensità è proporzionale alla conduttività del materiale.



# Metodo *ELETTROMAGNETICO*



ESERCITO

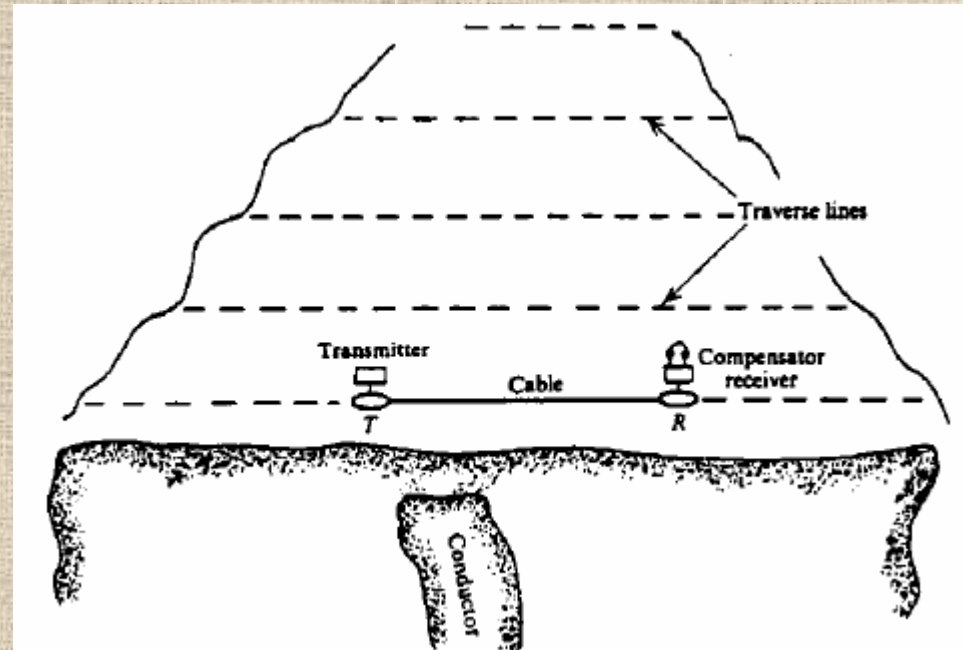
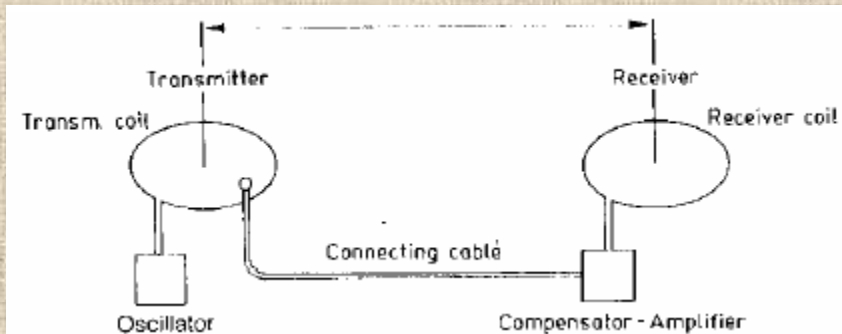



# Metodo *ELETTROMAGNETICO*



ESERCITO

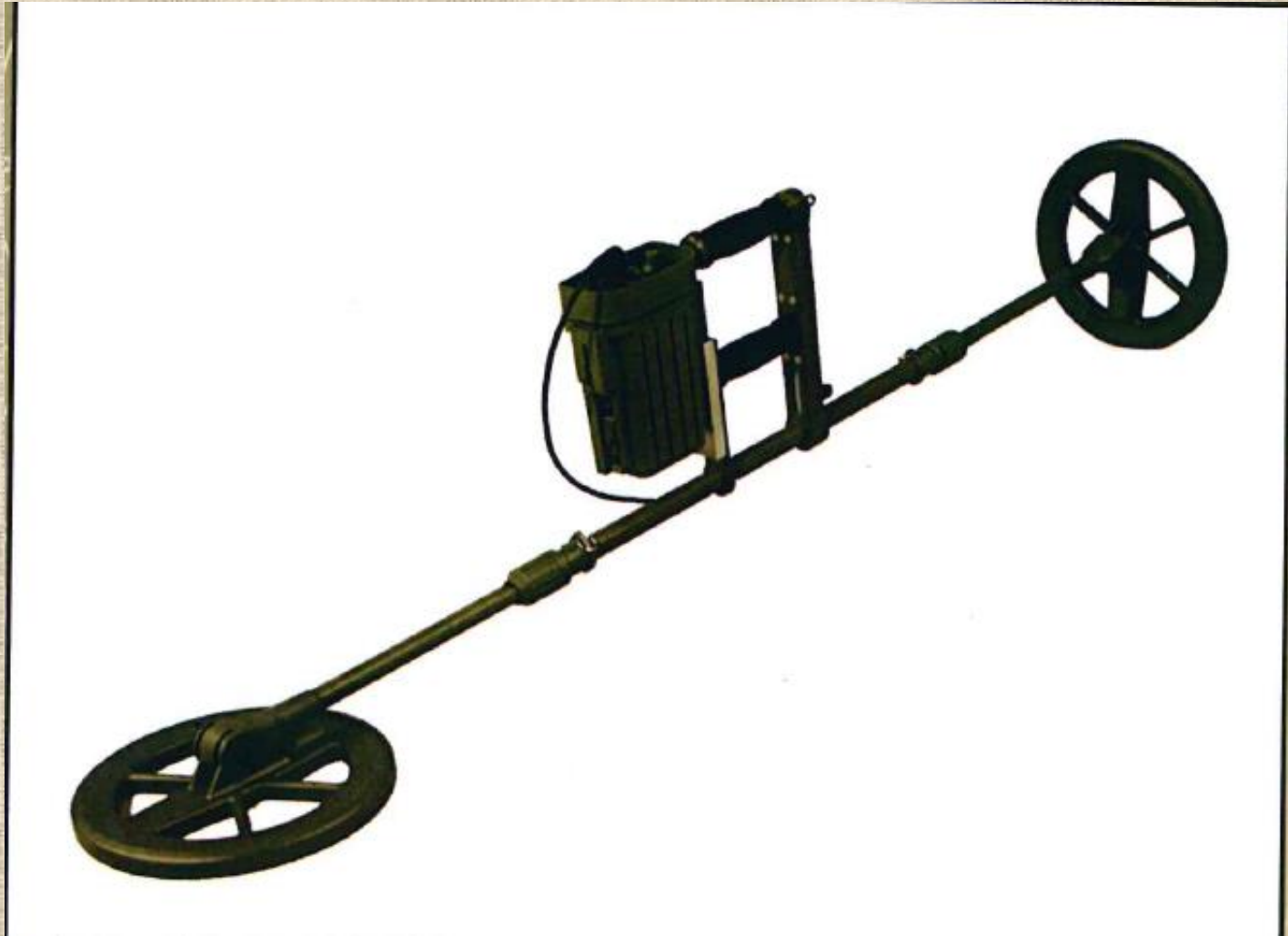





# Metodo *ELETTROMAGNETICO*



ESERCITO

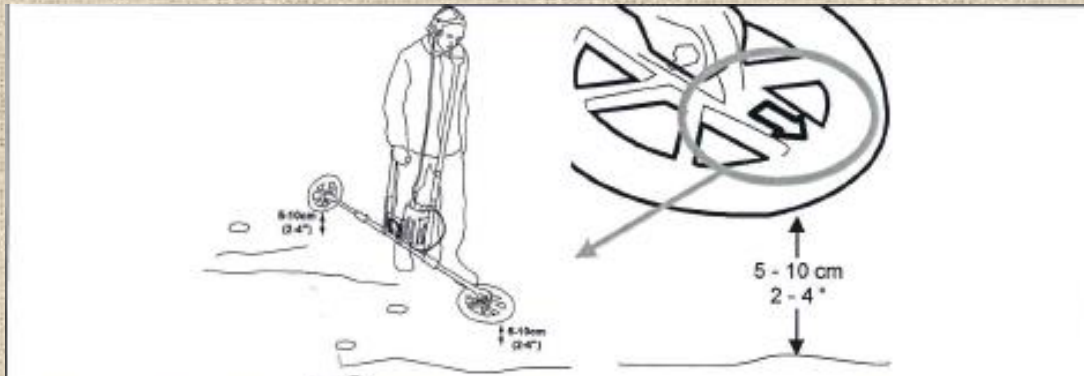

Avanzare lentamente, mantenendo la testa di ricerca anteriore davanti a sé e ad una distanza dal suolo di 5-10 centimetri. La testa di ricerca posteriore deve trovarsi alla medesima distanza dal suolo.

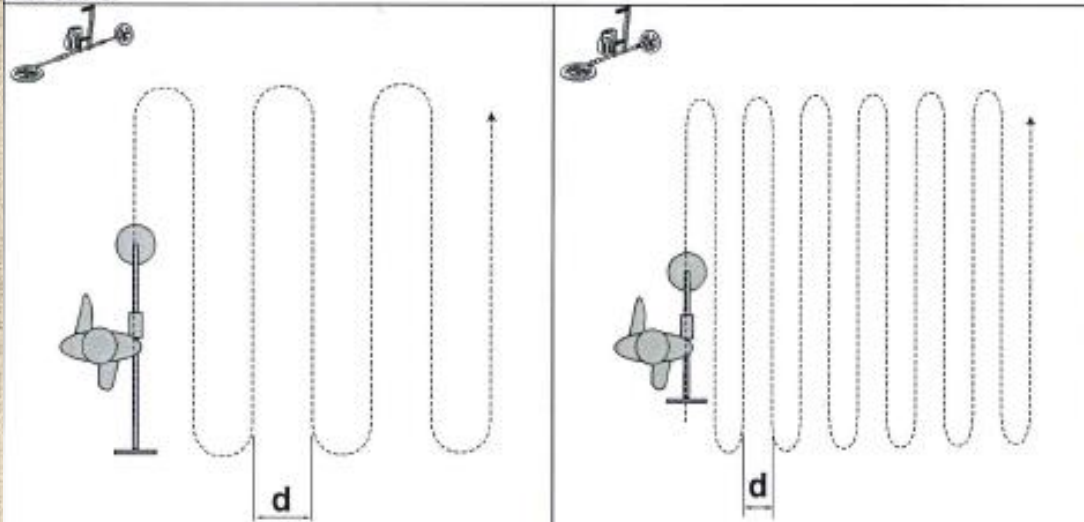

**Palo completamente esteso:  $d \leq 40\text{cm}$**

**Palo con lunghezza ridotta:  $d \leq 20\text{cm}$**

Le figure mostrano come ispezionare un'area di terreno. Utilizzando la configurazione ad alta sensibilità, le traiettorie percorse devono essere più vicine tra loro.



# Metodo *ELETTROMAGNETICO*



ESERCITO

Display	Suoneria/Cuffia	Dimensione della massa intercettata	
		 Nessuna massa metallica	
	Singolo impulso (ogni 4 secondi)	Funzionamento normale. Nessun allarme.	
	Segnale sonoro continuo, con volume crescente.	 Piccola massa metallica o ...	 ... grande massa metallica in profondità.
		Indicazione intermittente con cadenza lenta, con volume crescente.	
	Indicazione intermittente con cadenza veloce, con volume crescente.	 Massa metallica di medie dimensioni.	
		 Massa metallica di grandi dimensioni.	



# Metodo *ELETTROMAGNETICO*



ESERCITO

## 5.4.3. Localizzazione di una massa metallica (Pin-pointing)

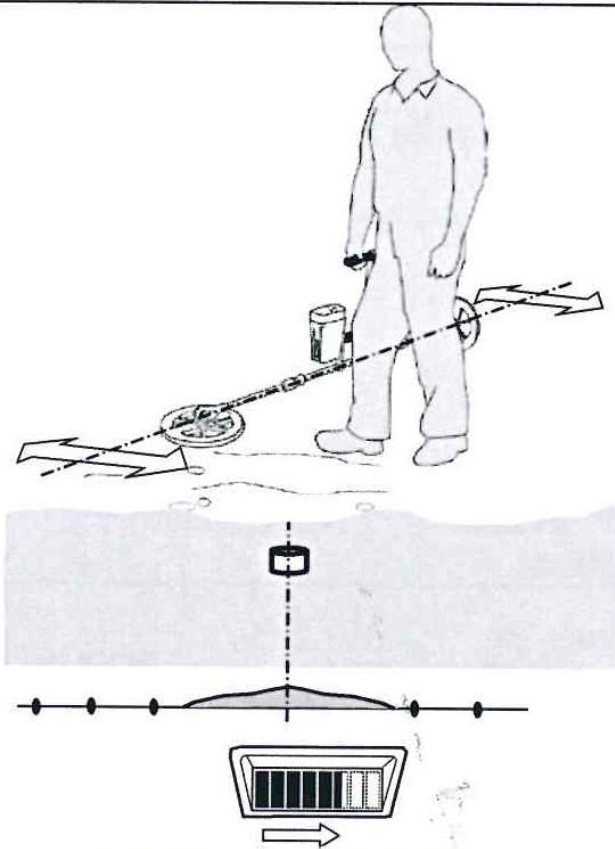

### Regola generale

Il volume del segnale sonoro cambia sensibilmente quando l'unità elettronica di controllo passa esattamente al di sopra della massa metallica; anche l'indicazione a bargraph sul display aumenta in modo analogo.

La localizzazione della massa metallica si ottiene quindi identificando il punto con segnalazione più elevata.



# Metodo *ELETTROMAGNETICO*



ESERCITO

Procedura

Ispezione Standard

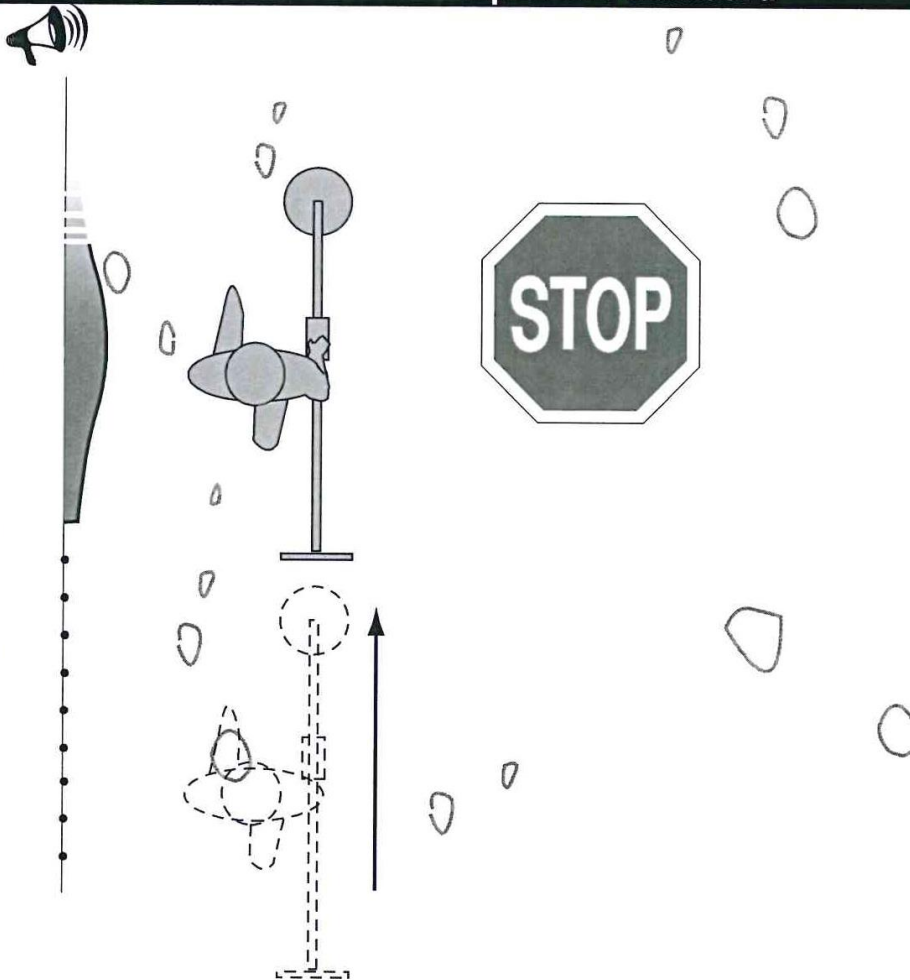

Avanzare normalmente e arrestarsi quando compare una segnalazione acustica.



# Metodo *ELETTROMAGNETICO*



ESERCITO

## Localizzazione (Pin-Pointing )

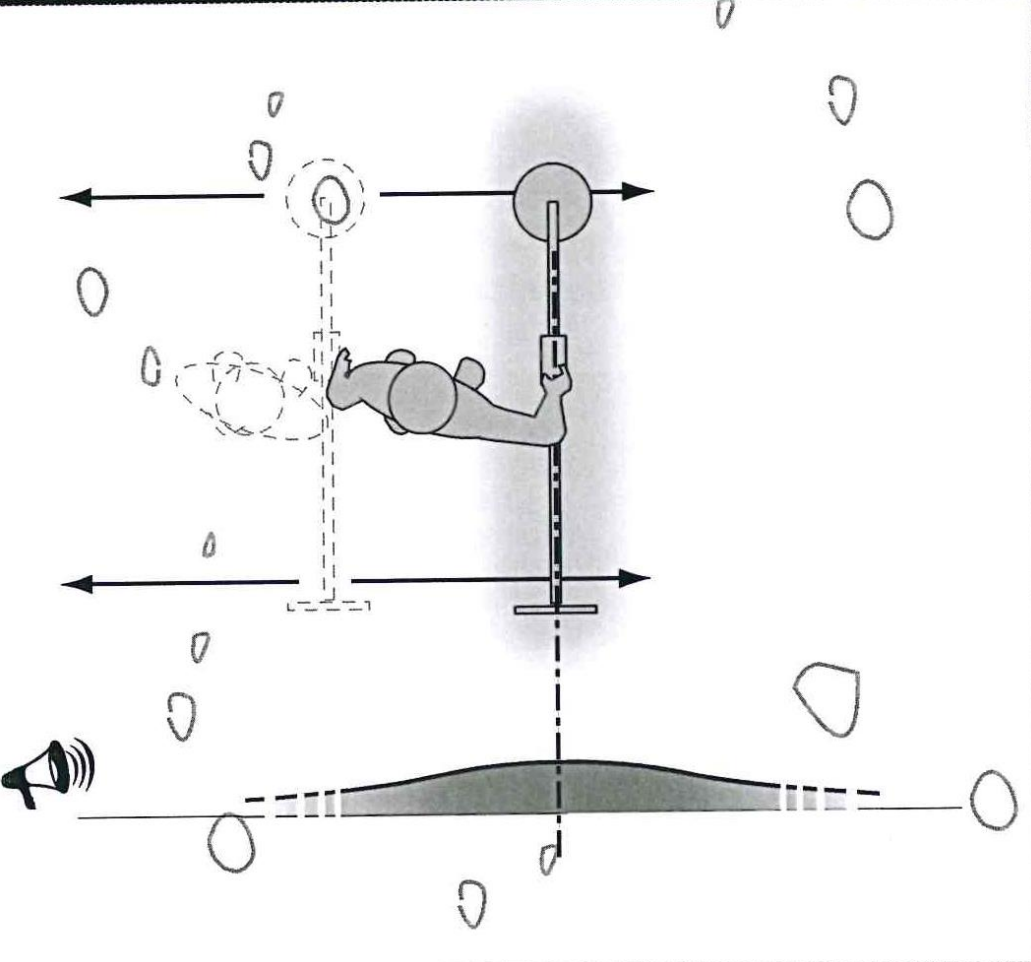
Fase ALPHA
 <p>Spostarsi lateralmente nei due sensi, per determinare la <b>direzione</b> corrispondente alla massima segnalazione: la massa si troverà lungo tale direzione.</p>



# Metodo *ELETTROMAGNETICO*



ESERCITO

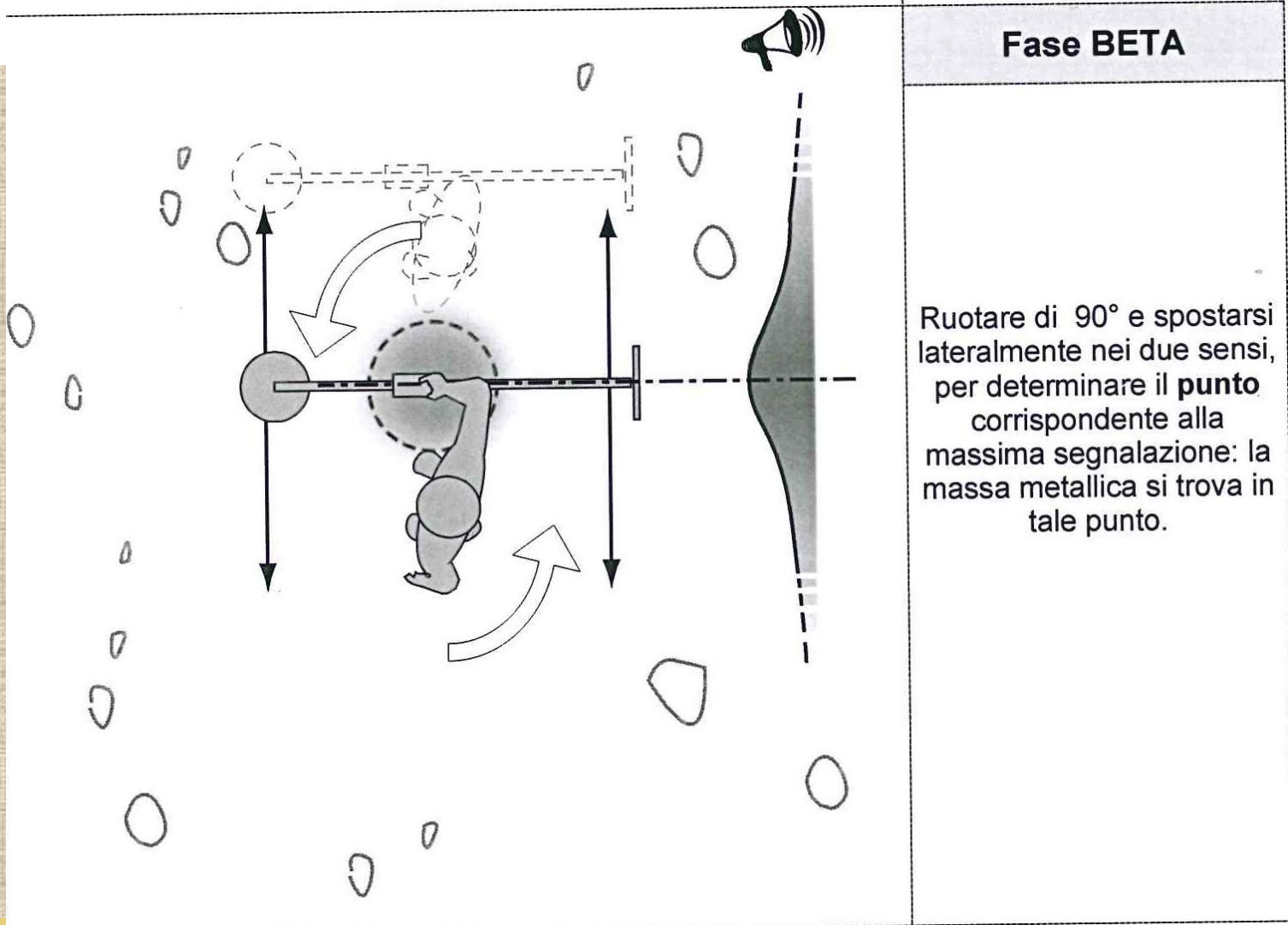



# Metodo *ELETTROMAGNETICO*

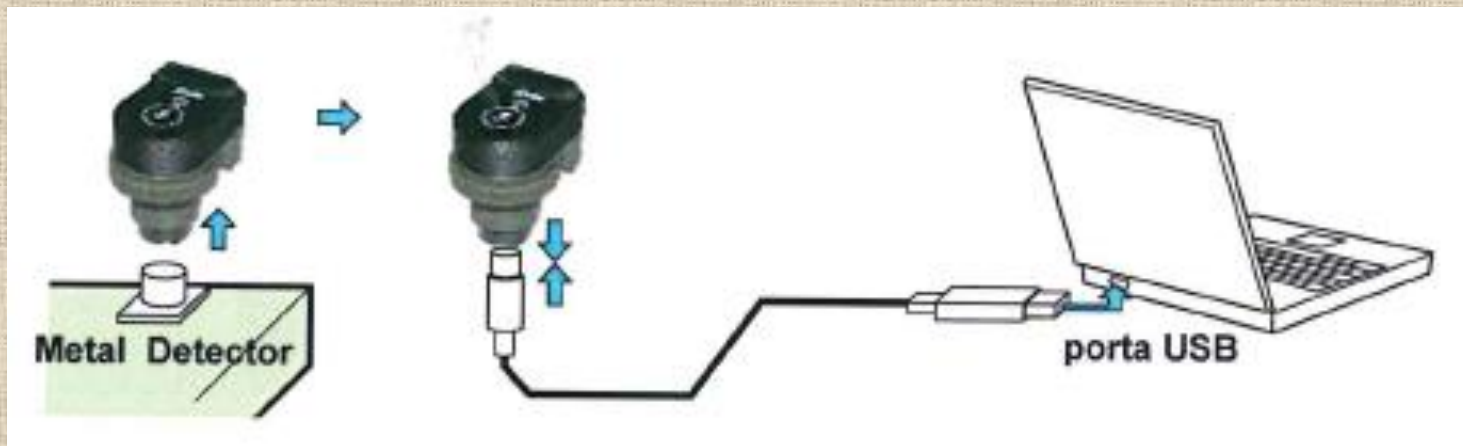



# Metodo *ELETTROMAGNETICO*



ESERCITO

marcati con un quadratino di colore giallo/arancio/rosso (rispettivamente, livello di allarme basso/medio/alto).

Zone marcate dall'operatore come punti d'interesse sono indicate dal simbolo . Cliccando su ogni punto della linea, compare la lista dei dati corrispondenti, inclusa, in caso d'allarme, l'ampiezza del segnale del Metal Detector.

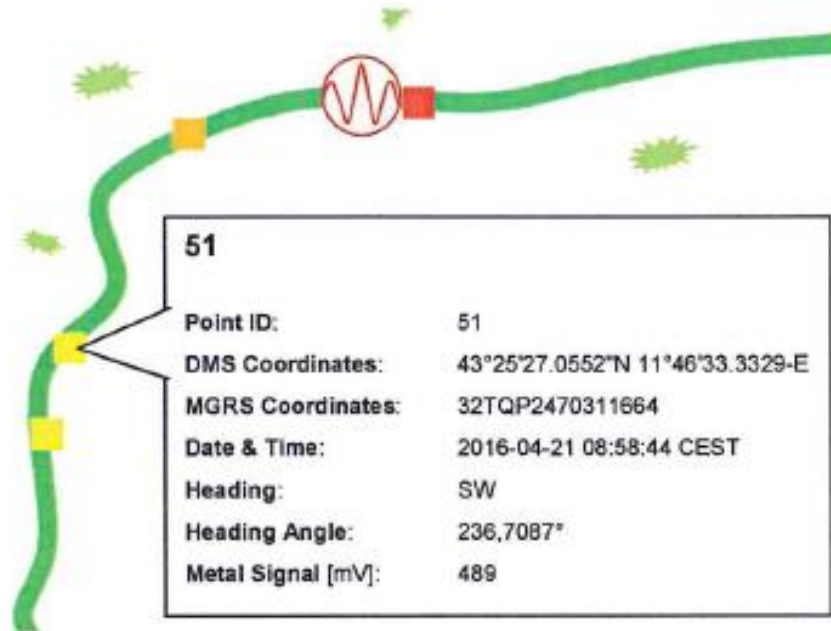





# Metodo *ELETTROMAGNETICO*

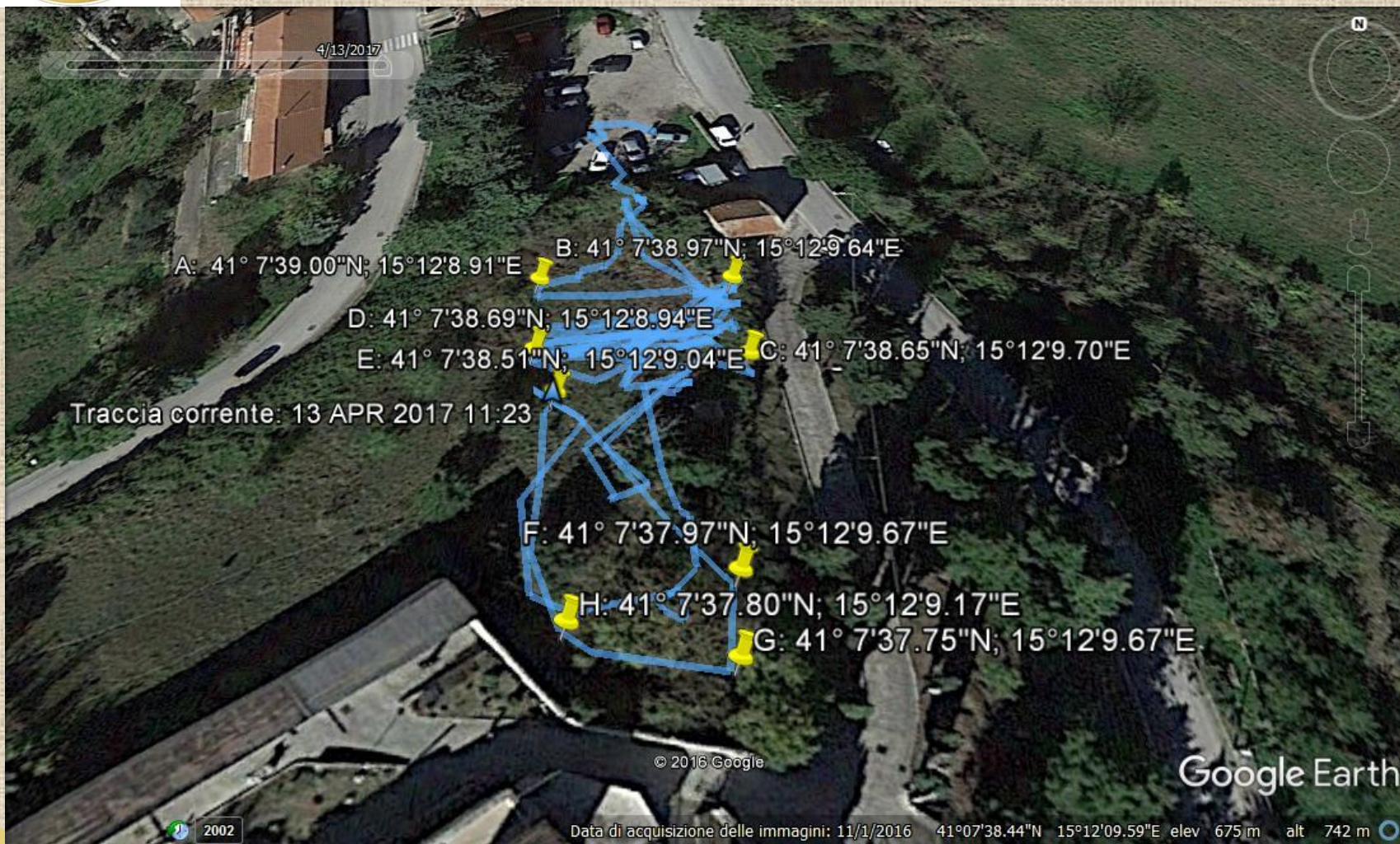



# CONCLUSIONE



**SPERANDO DI AVER FORNITO UN QUADRO  
CHIARO ED ESAUSTIVO**



**SIAMO A DISPOSIZIONE  
PER EVENTUALI DOMANDE**



**FINE**